

1

2

3

4

REV	ECN#	DESCRIPTION OF REVISION	DRAW BY DATE	CHECK BY DATE	APPROVE BY DATE
A2	ECN-180729	RR-ASCV-XXG=>RR-ASCV-XXGRC	Lucas 07/30/18	Lucas 07/30/18	Ray 07/30/18

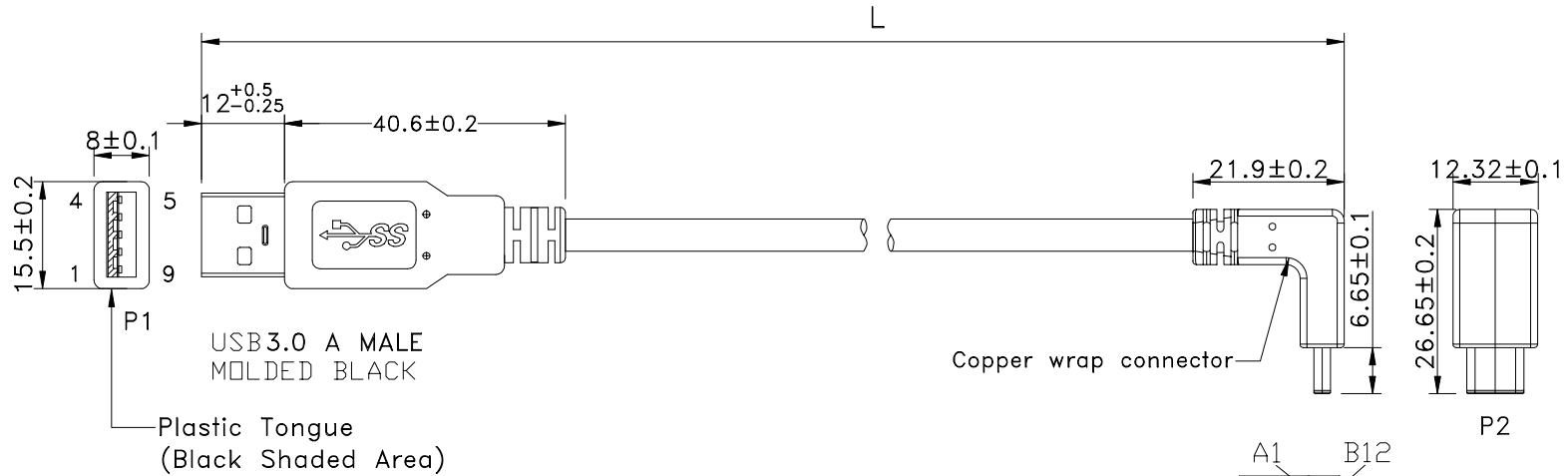

PIN OUT

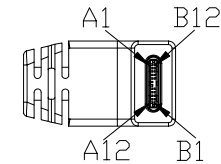
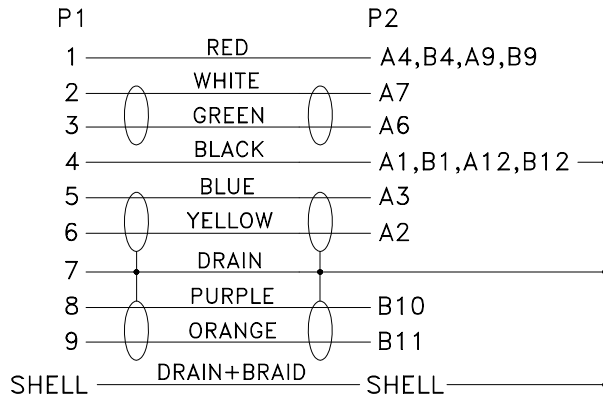

USB 3.1 C MALE RIGHT ANGLE UP/DOWN MOLDED BLACK

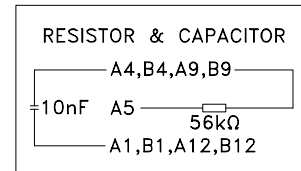

P/N	LENGTH
RR-ASCV-05GRC	127 ⁺²⁰ ₋₀
RR-ASCV-10GRC	255 ⁺²⁰ ₋₀
RR-ASCV-15GRC	381 ⁺³⁰ ₋₀
RR-ASCV-25GRC	635 ⁺³⁰ ₋₀
RR-ASCV-40GRC	1016 ⁺⁴⁰ ₋₀

TITLE USB3.0 AM TO USB3.1 C TYPE MALE RIGHT ANGLE UP/DOWN						DRAWING NUMBER RR-ASCV-XXGRC				REV. A2	
	B	1:1	Lucas 12/28/15	Ray 12/28/15	Ray 12/28/15	X.X ± 0.5	X.XX ± 0.2	X.XXX ± 0.05	ANGLES ± 1°	mm	1/3
THIRD ANGLE PROJECTION	SIZE	SCALE	DRAW / DATE	CHECK / DATE	APPROVE / DATE	TOLERANCES			UNIT	SHEET	

THE INFORMATION CONTAINED HEREIN IS THE PROPRIETARY PROPERTY OF GT Contact CO.,LTD THE POSSESSOR AGREES TO THE FOLLOWING:
 (C) TO MAINTAIN THIS DOCUMENT IN CONFIDENCE
 (D) NOT TO REPRODUCE OR COPY IT
 (E) NOT TO REVEAL OR PUBLISH IT IN WHOLE OR PART
 (F) ALL RIGHTS RESERVED

1

2

3

4

1

2

3

4

REV	ECN#	DESCRIPTION OF REVISION	DRAW BY DATE	CHECK BY DATE	APPROVE BY DATE
A2	ECN-180729	RR-ASCV-XXG=>RR-ASCV-XXGRC	Lucas 07/30/18	Lucas 07/30/18	Ray 07/30/18

***CONSTRUCTION:

1.CABLE: * UL2725 (1P/30#+EAM)*2+(1P/30#)+(2C/24#)+AEB(AL)65% OD:5.0mm
BLACK PVC JACKET.

***CONNECTOR:

2.USB A/M: * USB A "3.0" TYPE 9PIN MALE SOLDER TYPE.(NEW-CONN P/N:06801508M5CA)
* PINS: 30u GOLD PLATED OVER NICKEL.
* INSULATOR: BLUE COLOR P.B.T UL 94V-0 RATED.
* SHELL: STEEL WITH GOLD FLASH .
* MOLDED: BLACK PVC 45P.

3.USB C/M: * USB TYPE C MALE SOLDER TYPE.
* PINS: 30u GOLD PLATED OVER NICKEL.
* INSULATOR: BLACK THERMOPLASTIC UL 94V-0.
* SHELL: STEEL WITH GOLD FLASH.
* RESISTOR(56KΩ) AND CAPACITOR(10nF 30V).
* MOLDED: BLACK PVC 45P.

4.TEST: * CT: 2 ohm IS: 5M ohm DC300V 0.1S
5.PACKING: * PACK EACH CABLE IN A POLY BAG AND 25PCS IN A POLY BAG.
6.MATERIAL: * MATERIAL WITH RoHS GRADE.

TITLE USB3.0 AM TO USB3.1 C TYPE MALE RIGHT ANGLE UP/DOWN					DRAWING NUMBER RR-ASCV-XXGRC			REV. A2	
--	--	--	--	--	---------------------------------	--	--	------------	--

	B	1:1	Lucas 12/28/15	Ray 12/28/15	Ray 12/28/15	X.X ± 0.5 X.XX ± 0.2	X.XXX ± 0.05 ANGLES ± 1°	mm	2/3
THIRD ANGLE PROJECTION	SIZE	SCALE	DRAW / DATE	CHECK / DATE	APPROVE / DATE	TOLERANCES		UNIT	SHEET



THE INFORMATION CONTAINED HEREIN IS THE PROPRIETARY PROPERTY OF GT Contact CO.,LTD THE POSSESSOR AGREES TO THE FOLLOWING:
 (1) TO MAINTAIN THIS DOCUMENT IN CONFIDENCE
 (2) NOT TO REPRODUCE OR COPY IT
 (3) NOT TO REVEAL OR PUBLISH IT IN WHOLE OR PART
 (4) ALL RIGHTS RESERVED

1

2

3

4