

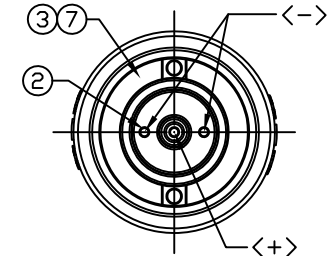

Notes: (Unless Otherwise Specified)

1. DWV: 500 Vrms
2. Rated Voltage: 30V AC/DC
3. Insulation Resistance: 100 MΩ MIN.
4. RoHS Compliant.

REV	ECN#	DESCRIPTION OF REVISION	DRAW BY DATE	CHECK BY DATE	APPROVE BY DATE
02	ECN-200123	 Modify Item No.7 Steel Sheet Material SUS --> SUS430	Hank 01/30/20	Lucas 01/30/20	Ray 01/30/20

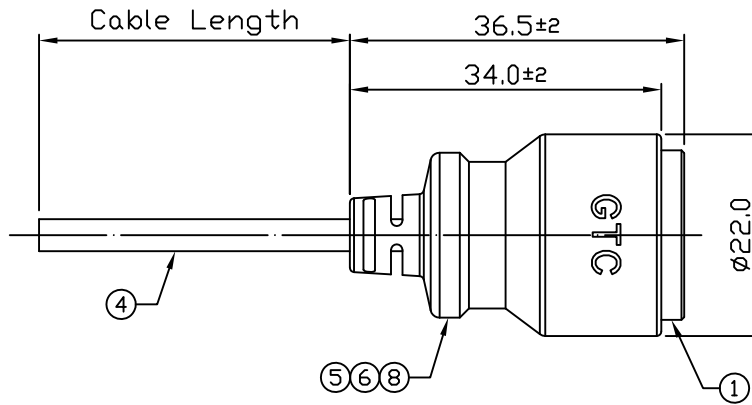

GTC
DOC.CENTER.ISSUE
FEB.03.2020
ONLY FOR
RELEASE

8	Wire	UL1007 18AWG Color: Black	1
7	Steel Sheet	SUS430 Finish: -	2 
6	Over Mold	PVC Color: Black	1
5	Inner Mold	Thermoplastic Color: White or Black	1
4	Cable	UL1185 18AWG*1C+Spiral ØD=3.5mm, Color: Black	1
3	Magnet	Nd-Fe-B N50 Finish: Ni	2
2	Contacts	Copper Alloy Finish: Au Plated	3
1	Housing	Thermoplastic Color: Black	1
Item	Part Name	Material / Finish	Q'ty

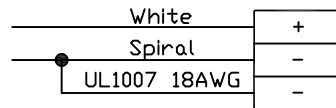

Wiring Diagram

RR-193110-02021-158	4013 mm	+150
RR-193110-02021-78	1981 mm	+100
Part No.	Cable Length	Tol.

TITLE						DRAWING NUMBER			REV.	
5A 2 Contacts Cable End With Cable						RR-193110-02021-XX			02	
	B	1:1	Hank 06/05/19	Lucas 06/05/19	Ray 06/05/19	X.X ± 0.5	X.XXX ± 0.05	mm	1/1	
THIRD ANGLE PROJECTION						TOLERANCES			SHEET	

USBFIREWIRE.com

THE INFORMATION CONTAINED HEREIN IS PROPRIETARY AND CONFIDENTIAL TO RR BUSINESS VENTURES, LLC. THE POSSESSOR AGREES TO THE FOLLOWING

1. MAINTAIN THIS DOCUMENT IN CONFIDENCE
2. NOT TO REPRODUCE OR COPY IT
3. NOT TO REVEAL OR PUBLISH IT IN WHOLE OR PART